

**CS1 Series, C200HX/HG/HE, C200HS, C200H  
C200HW-NC113, C200HW-NC213, and C200HW-NC413**

# **Position Control Unit**

## **Specification Sheets**

**OMRON**

# CS1 Series, C200HX/HG/HE, C200HS, C200H Position Control Unit

C200HW-NC113, C200HW-NC213, and C200HW-NC413

## One-axis, Two-axis, and Four-axis Position Control Units Capable of Memory Operation or Direct Operation

- The C200HW-NC113, C200HW-NC213, and C200HW-NC413 are one-axis, two-axis, and four-axis Position Control Units for the CS1-Series, C200HX/HG/HE, C200HS, and C200H PCs. These Units receive instructions from the CPU Unit and output pulses to various motor drivers for positioning.

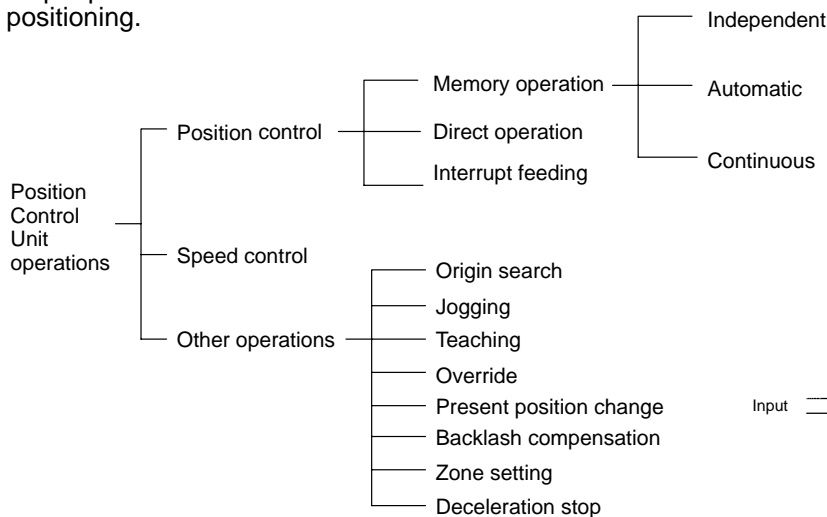

C200HW-NC113/NC213/NC413

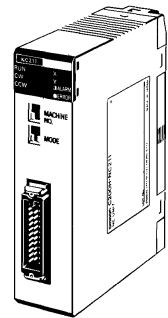

## System Configuration Example

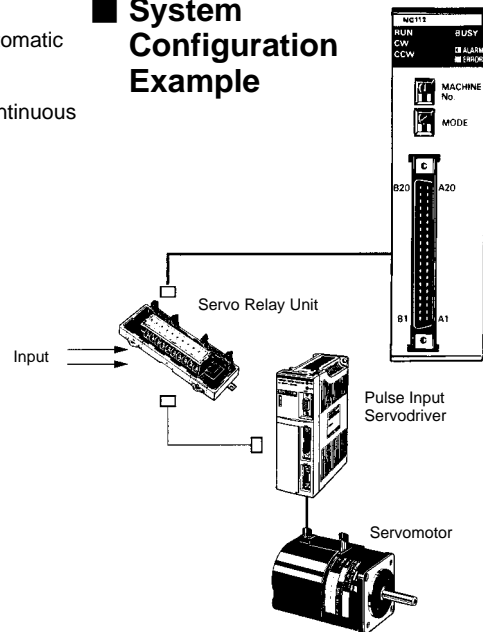

## Features

### Memory Operation and Direct Operation

Operation can be controlled through memory operation, where data for positioning is transferred to the Position Control Unit and then specified for position control, or through direct operation, where target positions and speeds are set each time from the CPU Unit. Combining these methods is also possible, allowing a Position Control Unit to perform flexible positioning operations ranging from easy to complicated.

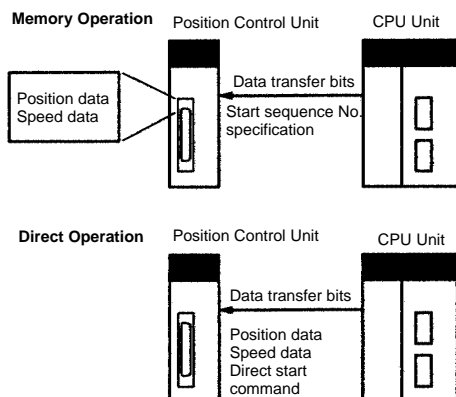

## Various Basis Functions

The C200HW-NC113, C200HW-MC213, and C200HW-413 support various basic functions, such as origin searches, interrupt feeding, speed controls, jogging, teaching, overrides (speed coefficients), backlash compensation, present position changes, zone settings, and deceleration stops.

## Enhanced Functions

The C200HW-NC113, C200HW-MC213, and C200HW-413 support the following functions that the previous models (C200H-NC211 and C200H-NC112) do not support.

- Direct operation is possible.
- S-curve acceleration/declaration is possible in addition to trapezoidal acceleration/declaration.
- Speed control is possible.
- Backlash compensation speed can be specified.
- Forced intervention is possible (specified position data can be forcibly executed).
- Flash memory operation is possible.

"Programmable Controller" is abbreviated as "PC" in these *Specification Sheets*.

**Compact Size**

The single-axis, two-axis, and four-axis models are all one compact size.

**Special Support Software for CS1-Series and C200HX/HG/HE PCs)**

Special Support Software, the SYSMAC-NCT, which runs on Windows 95, allows the user to easily create various data for the Position Control Unit. It can also be used for writing data to the PCU, reading data from the PCU, saving data, and printing data.

**Easy Data Transfer**

Position data used for memory operation can be transferred to the Position Control Unit by using the NC Support Software (for CS1-Series and C200HX/HG/HE PCs only), data transfer bits, and the Intelligent I/O Write (IOWR) and Intelligent I/O Read (IORD) instructions (for CS1-Series and C200HX/HG/HE PCs only).

**ROM Operation by Flash Memory**

Position data used for memory operation can be stored in the flash memory in the Position Control Unit. It is retained even when the power is turned OFF. So, there is no need for battery maintenance.

■ **Models**

Applicable PCs	Unit classification	Number of control axes	Controlled driver	Model number
CS1, C200HX/HG/HE, C200HS, and C200H PCs	C200H Special I/O Unit	1 axis	Pulse-train input driver or stepping motor driver	C200HW-NC113
		2 axes		C200HW-NC213
		4 axes		C200HW-NC413

**Support Software (Sold Separately)**

Name	System requirements	Applicable PCs	Specifications	Model
SYSMAC-NCT	Personal computer: IBM AT or compatible Operating system: Windows 95 Minimum memory: 16 MB Available disk space: 10 MB min.	CS1-Series and C200HX/HG/HE PCs only (Cannot be used with C200H or C200HS PCs.)	Creating positioning data and parameter data, transferring data to the Unit, writing data to the flash memory, and printing Unit status monitor data, positioning data, and parameter data	WS01-NCTF1-E
Connecting Cable	For connecting the RS-232C port on the CPU Unit	2.0 m, 5.0 m		XW2Z-□□□□ (For details, refer to □ optional parts.)

■ **Specifications**

Item	Specifications			
	C200HW-NC113	C200HW-NC213	C200HW-NC413	
Applicable PCs	CS1-Series, C200HX/HG/HE, C200HS, C200H			
Unit classification	C200H Special I/O Unit			
Mounting location	CPU Rack, C200H Expansion I/O Rack, CS1 Expansion Rack, SYSMAC BUS Remote I/O Slave Unit			
Maximum number of Units that can be mounted	16 or 10 Units depending on the CPU Unit model (refer to <i>Connectable CPU Unit Models</i> ).		8 or 5 Units depending on the CPU Unit model (refer to <i>Connectable CPU Unit Models</i> ).	
Unit numbers	0 to F or 0 to 9 depending on the CPU Unit model (refer to <i>Connectable CPU Unit Models</i> ).		0 to 8, or 0 to 8 and A to E depending on the CPU Unit model (refer to <i>Connectable CPU Unit Models</i> ).	
Data exchange area with CPU Unit	Words allocated in the Special I/O Unit Area	5 words/Unit	10 words/Unit	
		CPU Unit → Position Control Unit: Operating commands (sequence numbers, start, origin search, etc.) Position Control Unit → CPU Unit: Status (positioning completed, present position, etc.)		
	DM area words allocated to Special I/O Units	100 words/Unit		
		CPU Unit → Position Control Unit: Common parameters and axis parameters (I/O selection, operation mode selection, start speed, origin search speed, acceleration/deceleration time, etc.)		
Controlled driver	Pulse-train input type Servodriver or stepping motor driver			
Control	Control system	Open-loop control by pulse train output (automatic trapezoidal or S-curve acceleration/deceleration)		
	Number of control axes	1 axis	2 axes	4 axes
Control unit	Pulse			

Item	Specifications			
	C200HW-NC113	C200HW-NC213	C200HW-NC413	
Positioning operations	Two types: Memory operation and direct operation			
	Memory operation: Transfers sequence data such as position data and speed data to the Position Control Unit beforehand, and executes positioning in ascending order of sequence numbers by specifying the start sequence number from the CPU Unit.			
	Completion code of each sequence for memory operation: Independent, automatic, continuous, bank end, speed control (continuous output), or interrupt feeding (continuous output with positioning) can be specified.			
	Direct operation: Writes position data and speed data to the specified area in the CPU Unit and executes positioning by outputting the data to the Position Control Unit through I/O refresh.			
	Speed control and interrupt feeding are also possible.			
	Independent	1 axis	2 independent axes	4 independent axes
	Linear interpolation	–	2 axes max.	4 axes max.
	Speed control	1 axis	2 independent axes	4 independent axes
	Interrupt feeding	1 axis	2 independent axes	4 independent axes
Positions	Range	–9,999,999 to 9,999,999 pulses		
	Data items	100/axis		
Speeds	Range	1 pps to 500 Kpps		
	Data items	100/axis		
Acceleration and deceleration times	Range	0 to 250 s, until maximum speed is reached.		
	Data items	9/axis for acceleration and deceleration each.		

Item		Specifications		
		C200HW-NC113	C200HW-NC213	C200HW-NC413
Functions	Origin search	Origin proximity input signal: selectable (absent, N.O. or N.C. contact). Origin input signal: selectable (N.O. or N.C. contact) Origin compensation: -9,999,999 to 9,999,999 pulses Origin search speed: High-speed or proximity-speed can be set. Origin search method: May be set to stop upon origin input signal after proximity input signal has turned ON, to stop upon origin input signal after proximity input signal has turned OFF, to stop upon origin input signal without using proximity input signal, or to stop upon origin input signal after limit input signal has turned OFF. N.O. = Normally open N.C. = Normally closed		
	Origin search operation mode	0 (Mode 0)	Stepping motors are used and external sensor signals are used as origin input signals. In this case, error counter reset output and origin-adjustment command output can be used as general-purpose outputs.	
		1 (Mode 1)	Servodrivens are used and encoder phase-Z signals are used as origin input signals. The Servodriver's positioning completed signals are not used.	
		2 (Mode 2)	Servodrivens are used and encoder phase-Z signals are used as origin input signals. The Servodriver's positioning completed signals are used.	
		3 (Mode 3)	Servodrivens such as OMRON H-Series and M-Series are used. The Servodriver's origin-adjustment command is used to complete origin search. The Servodriver's positioning completed signals are used.	
	Jogging	Jogging can be executed at a specified speed.		
	Dwell times	19/axis can be set from 0 to 9.99 s (unit: 0.01 s).		
	Acceleration/ deceleration curves	Trapezoidal or S-curve (Can be set separately for each axis.)		
	Zones	Zone Flag turns ON when present position is within a specified zone. Three zones can be set for each axis.		
	Software limit	Can be set within a range of -9,999,999 to 9,999,999 pulses.		
	Backlash compensation	0 to 9,999 pulses. Compensation speed can also be set.		
	Teaching	With a command from the CPU Unit, the present position can be taken as the position data.		
	Forced intervention	Stops the active sequence and executes the specified sequence No. (Valid during memory operation only)		
	Deceleration stop	The STOP command causes positioning to decelerate to a stop according to the specified deceleration time.		
	Present position change	The PRESENT POSITION CHANGE command can be used to change the present position to a specified value.		
	Override	When the override enabling command is executed during positioning, the target speed is changed by applying the override coefficient.		
	Pulse output prohibited	Prohibits pulse output when emergency stop, CW limit, CCW limit, or CW/CCW software limit input turns ON.		
	Data transfer (data read/write)	Various data can be transferred to the memory in the Position Control Unit, using either of the following methods: 1) Data transfer bits 2) Intelligent I/O Write (IOWR) and Intelligent I/O Read (IORD) instructions (for CS1-Series and C200HX/HG/HE PCs only) 3) SYSMAC-NCT Support Software (for CS1 Series and C200HX/HG/HE PCs only)		
	Data saving	Various data can be saved in the internal flash memory. If data is saved, the Position Control Unit can be operated using the saved data when it is turned ON or restarted. There is no need to transfer data to the Unit each time. Note: Flash memory life expectancy: 100,000 times (reads/writes)		

Item		Specifications		
		C200HW-NC113	C200HW-NC213	C200HW-NC413
External I/O	Inputs	Prepare the following inputs for each axis: CW and CCW limit input signals, origin proximity input signal, origin input signal (see note), emergency stop input signal, positioning completed signal, interrupt input signal  Voltage: 24 VDC ±10% Current: 4.3 mA (at 24 V) typ. ON voltage: 17.4 VDC min. OFF voltage: 5.0 VDC max. ON response time: 1 ms max. (0.1 ms max.: Interrupt input) OFF response time: 1 ms. max.  The following information applies to origin input only. External signal is open-collector signal: Same as above, except for response time (N.O. contact: 0.1 ms max.; N.C. contact: 1 ms max.) External signal is line-driver signal: Corresponds to line driver signals equivalent to Am26LS31, except for response time (N.O. contact: 0.1 ms max.; N.C. contact: 1 ms max.)		
	Outputs	Prepare the following outputs for each axis: Pulse outputs (open collector outputs) CW/CCW pulses, pulse outputs and direction outputs can be switched. Either error counter reset or origin-adjustment command outputs can be selected depending on the mode.  Maximum switching capacity: 30 mA at 4.75 to 26.4 VDC (NPN open collector) (16 mA: Terminals with 1.6-kΩ limit resistance) Minimum switching capacity: 7 mA at 4.75 to 26.4 VDC (NPN open collector) Leakage current: 0.1 mA max. Residual voltage: 0.6 V max. External power supply:           24 VDC ±10% C200HW-NC113: 30 mA max. C200HW-NC213: 50 mA max. C200HW-NC413: 90 mA max.		
Pulse output distribution period		4 ms		
Self-diagnostic function		Flash memory check, memory loss check, I/O bus check		
Error detection function		Overtravel, CPU error, software limit over, emergency stop		
Unit number setting switch		Rotary switch: Unit number (0 to F) (Differs depending on the CPU Unit model. Refer to <i>Connectable CPU Unit Models</i> .)		
LED indicators		Number of indicators: 5 (NC113), 6 (NC213), 8 (NC413) Show the PCU's status such as running state, error state, input signal state, data state, and each axis state.		
Connections on the front panel		X-axis connector	X/Y-axis connector	X/Y-axis connector, Z/U-axis connector
		Use the FCN-361J048-AU Connector (soldered) and the FCN-360C048-D Connector Cover provided. Also, use OMRON's Servodriver Connecting Cables.		
Internal current consumption (provided from Power Supply Unit)		300 mA max. at 5 VDC	300 mA max. at 5 VDC	500 mA max. at 5 VDC
Dimensions		130 x 34.5 x 100.5 mm (H x W x D) The height including the Backplane is 230 mm when the attached connector or OMRON's Servodriver Cable is used.		
Weight (excluding connectors)		250 g max.	300 g max.	350 g max.
Standard accessories		Fujitsu FCN-361J048-AU Connector (soldered) and FCN-360C048-D Connector Cover: 1 set		
Cat. No.		W334 (W324 for SYSMAC-NCT Support Software)		

**■ Options (Sold Separately)**

Item	Specifications		Model number
Connectors for each axis	Soldered (provided as standard on this Unit)	Soldered connector	FCN-361J048-AU
		Connector cover	FCN-360C048-D
	Crimp	Crimp-type housing	FCN-363J048
		Contact	FCN-363J-AU/S
		Connector cover	FCN-360C048-D

Item		Specifications			Model number		
The following cables and Servo Relay Units can be used to connect OMRON's Servodrivers.		Applicable Position Control Unit	Applicable OMRON Servodriver	Cable length	---		
		1 axis	Connecting Cable	C200HW-NC113	U-Series, H-Series, M-Series	50 cm	XW2Z-050J-A6
						100 cm	XW2Z-100J-A6
					UEP-Series only	50 cm	XW2Z-050J-A8
						100 cm	XW2Z-100J-A8
		Servo Relay Unit		Connects to the above cable.			XW2B-20J6-1B
		2 axes	Connecting Cable	C200HW-NC213 and C200HW-NC413 (Two cables are required for C200HW-NC413.)	U-Series, H-Series, M-Series	50 cm	XW2Z-050J-A7
						100 cm	XW2Z-100J-A7
					UEP-Series only	50 cm	XW2Z-050J-A9
						100 cm	XW2Z-100J-A9
Servo Relay Unit			Connects to the above cable. (Two Units are required for C200HW-NC413.)			XW2B-40J6-2B	

Item	Connection port	Personal computer	Cable length	Model
SYSMAC-NCT Support Software Connecting Cable	Connects to the RS-232C port on the CPU Unit (in Host Link Mode).	IBM AT or compatible	2.0 m	XW2Z-200S-V
			5.0 m	XW2Z-500S-V

■ Applicable CPU Units

PC	CPU Unit model	Total number of PCUs that can be mounted on CPU Racks, Expansion Racks, and SYSMAC BUS Remote I/O Slave Units (see note).		Unit mounting restrictions
		C200HW-NC113/NC213	C200HW-NC413	
<b>Position Control Unit</b>				
CS1 Series	CS1H-CPU□□□□ CS1G-CPU□□□□	16 (Unit No.: 0 to F)	8 (Unit No.: 0 to 8, A to E)	None
C200HX/HG/HE	C200HE-CPU11/32/42 (-ZE) C200HG-CPU33/43 (-ZE) C200HX-CPU34/44 (-ZE)	10 (Unit No.: 0 to 9)	5 (Unit No.: 0 to 8)	None
	C200HG-CPU53/63 (-ZE) C200HX-CPU54/64 (-ZE) C200HX-CPU65-ZE/85-ZE	16 (Unit No.: 0 to F)	8 (Unit No.: 0 to 8, A to E)	None
C200HS	C200HS-CPU01(-□)/21 (-□)/31/03/23/33	10 (Unit No.: 0 to 9)	5 (Unit No.: 0 to 8)	None
C200H	C200H-CPU01/02/03/11/21/2 2/23/31	10 (Unit No.: 0 to 9)	5 (Unit No.: 0 to 8)	Cannot be mounted in the two rightmost slots on the CPU Rack.

**Note:** Restrictions in Using SYSMAC BUS Remote I/O Slave Units  
 The maximum number of C200H Special I/O Units that can be mounted on a SYSMAC BUS Remote I/O Slave Unit differs according to the Units as shown below. C200H Special I/O Units can be divided into the following four groups according to the maximum number of Units that can be mounted.

Group	A	B	C	D
Units	ASCII Unit, High-speed Counter Unit, Position Control Unit (NC111/112/113/213), Analog I/O Unit, ID Sensor Unit, Fuzzy Logic Unit	High-density I/O Unit, Temperature Control Unit, PID Control Unit, Heating/Cooling Control Unit, Cam Positioner Unit	Temperature Sensor Unit, Voice Unit	Position Control Unit (NC211/413), Motion Control Unit
Maximum number of Units that can be mounted in each group under one Master Unit	4 Units	8 Units	6 Units	2 Units
Maximum number of Units that can be mounted in all groups	$3A + B + 2C + 6D \leq 12$ , AND $A + B + C + D \leq \times 8$			

■ System Configuration  
Control System: Open-loop System

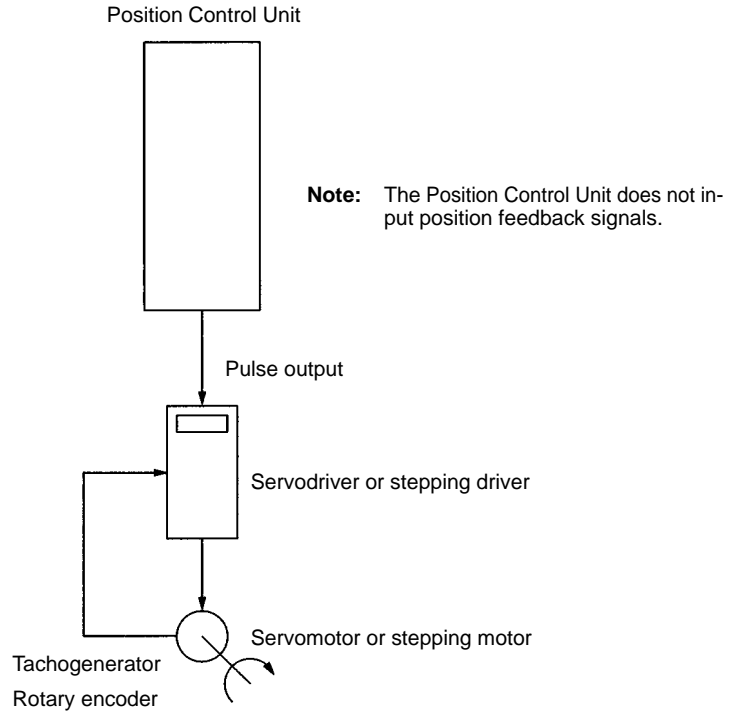

Connection Configuration

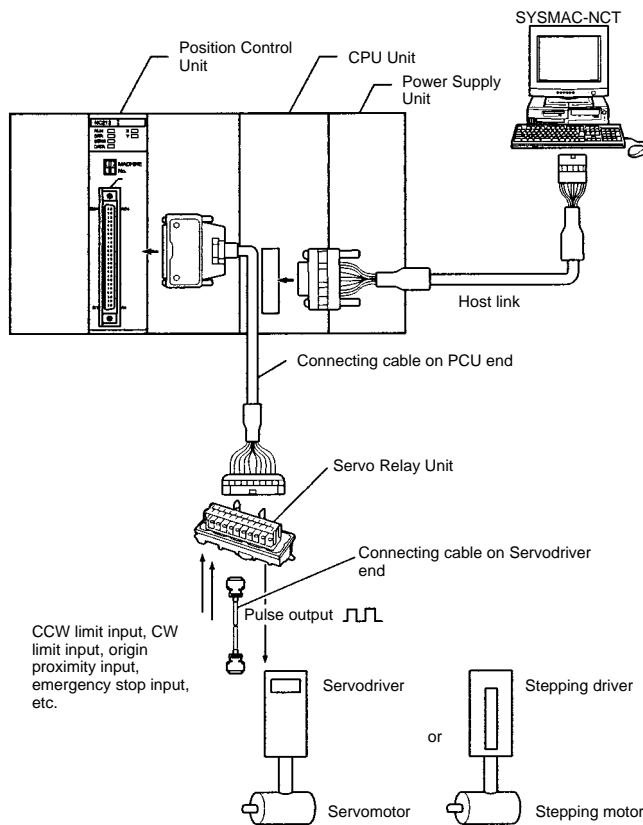

Item	1-axis	2/4-axis
Connecting cable on PCU end	XW2Z-□□□J-A□	XW2Z-□□□J-A□
Servo Relay Unit	XW2B-20J6-1B	XW2B-40J6-2B

+

Item	Connection to U-Series	Connection to M-Series	Connection to H-Series
Connecting cable on Servodriver end	XW2Z-□□□J-B1	XW2Z-□□□J-B2	XW2Z-□□□J-B3

+

Servodriver	U-Series	M-Series	H-Series
	R88D-UP□□□	R88D-MT□□□	R88D-H□□□



■ Exchanging Data

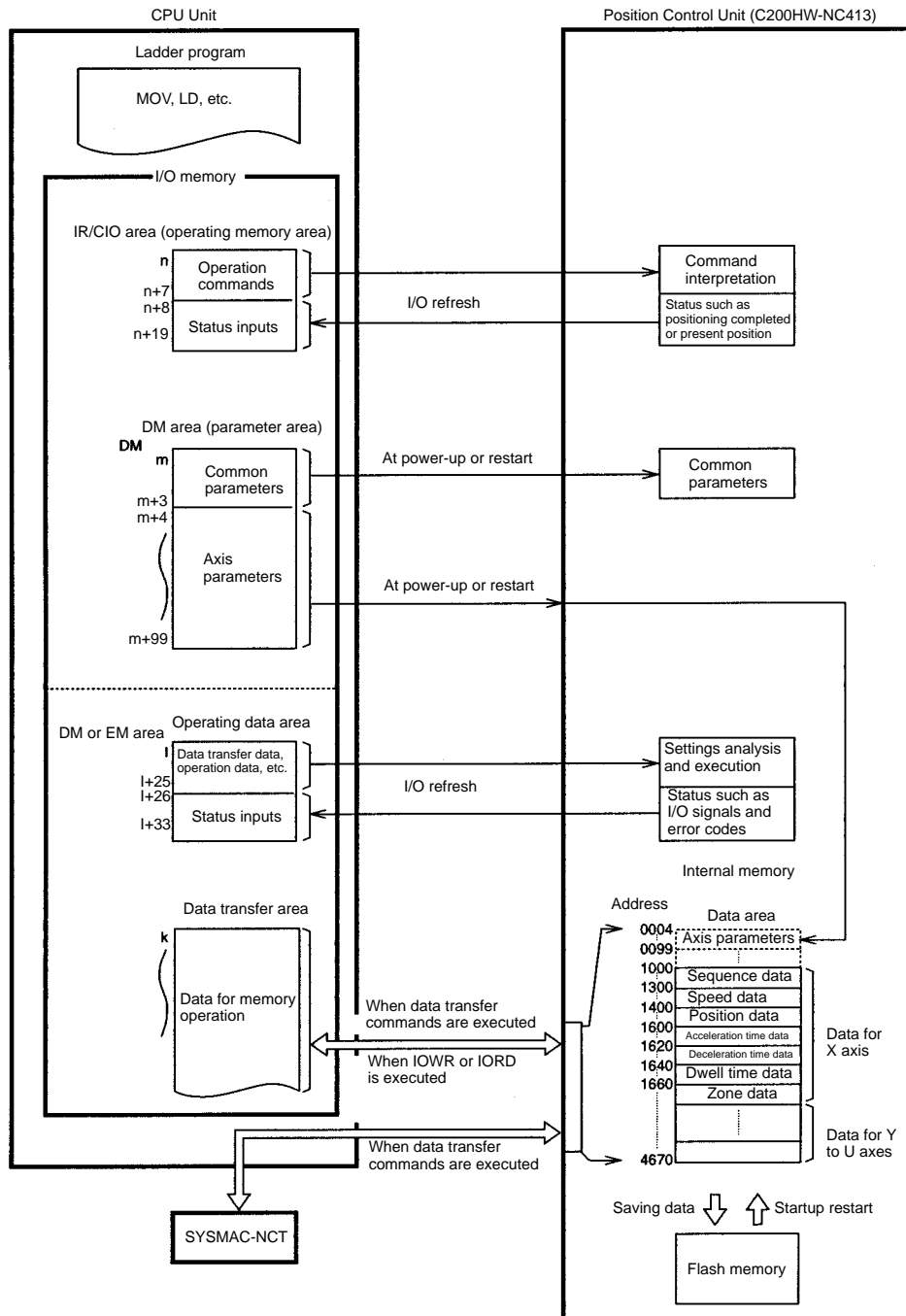

■ Components

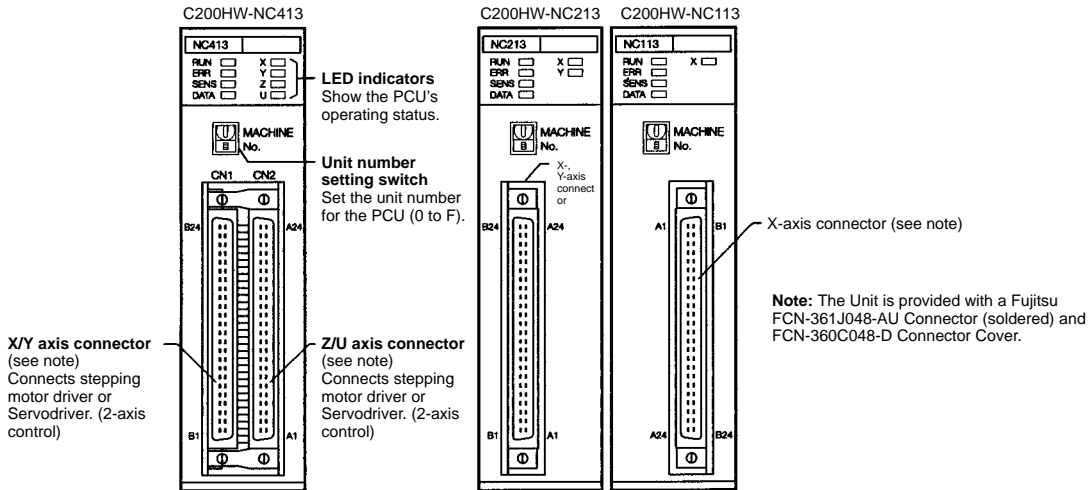

LED Indicators

Name	Color	Status	Explanation
RUN	Green	Lit	Lit during normal operation.
		Not lit	Hardware error, or PC notified of PCU error.
ERR	Red	Lit / flashing	An error has occurred.
		Not lit	No error has occurred.
SENS	Red	Lit	Either a CW/CCW limit signal or an emergency stop input signal is being input. At this time the LED indicator for the relevant axis (X to U) will flash.
		Flashing	Either a parameter loss, a data loss, or an operating data area designation error has occurred.
		Not lit	None of the above has occurred.
DATA	Red	Flashing	The check of all data (parameters, positions, etc.) following power up shows that data is lost or corrupted.
		Lit	Data is incorrect (e.g., the parameters or positions transferred are out of the permissible range). At this time the LED indicator for the relevant axis (X to U) will flash.
		Not lit	None of the above has occurred.
X	Orange	Lit	Pulses are being output to the X axis (either forward or reverse).
		Flashing	An error has occurred, such as incorrect cable type for the X axis or faulty data.
		Not lit	None of the above has occurred.
Y	Orange	Lit	Pulses are being output to the Y axis (either forward or reverse).
		Flashing	An error has occurred, such as incorrect cable type for the Y axis or faulty data.
		Not lit	None of the above has occurred.
Z	Orange	Lit	Pulses are being output to the Z axis (either forward or reverse).
		Flashing	An error has occurred, such as incorrect cable type for the Z axis or faulty data.
		Not lit	None of the above has occurred.
U	Orange	Lit	Pulses are being output to the U axis (either forward or reverse).
		Flashing	An error has occurred, such as incorrect cable type for the U axis or faulty data.
		Not lit	None of the above has occurred.

■ External I/O Connectors

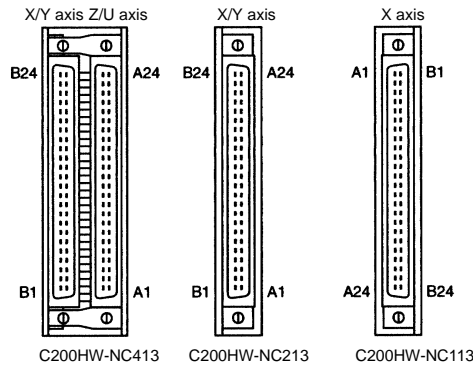

Connector Pin Numbers

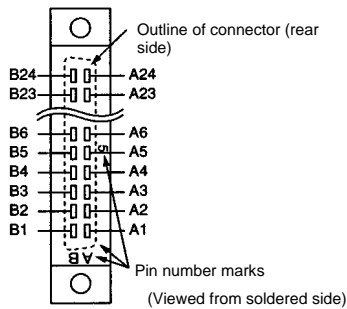

Connector Pin Arrangement for X and Z Axes

Pin No.	I/O	Name
A1	IN	Output power supply, 24 VDC
A2	IN	Output GND, 24 VDC
A3	--	Not used
A4	--	Not used
A5	OUT	CW pulse output
A6	OUT	CW pulse/pulse output with 1.6 KΩ resistance
A7	OUT	CCW pulse/direction output
A8	OUT	CCW pulse/direction output with 1.6 KΩ resistance
A9	--	Not used
A10	OUT	Error counter reset output Origin-adjustment command output
A11	OUT	Error counter reset output with 1.6 KΩ resistance Origin-adjustment command output with 1.6 KΩ resistance
A12	IN	Positioning completed input signal
A13	--	Not used
A14	IN	Origin common
A15	IN	Origin input signal (24 V)
A16	IN	Origin input signal (5 V)
A17	--	Not used
A18	--	Not used
A19	IN	Interrupt input signal
A20	IN	Emergency stop input signal
A21	IN	Origin proximity input signal
A22	IN	CW limit input signal
A23	IN	CCW limit input signal
A24	IN	Input common

Connector Pin Arrangement for Y and U Axes

Pin No.	I/O	Name
B1	IN	Output power supply, 24 VDC
B2	IN	Output GND, 24 VDC
B3	--	Not used.
B4	--	Not used.
B5	OUT	CW pulse output
B6	OUT	CW pulse/pulse output with 1.6 KΩ resistance
B7	OUT	CCW pulse/direction output
B8	OUT	CCW pulse/direction output with 1.6 KΩ resistance
B9	--	Not used.
B10	OUT	Error counter reset output Origin-adjustment command output
B11	OUT	Error counter reset output with 1.6 KΩ resistance Origin-adjustment command output with 1.6 KΩ resistance
B12	IN	Positioning completed input signal
B13	--	Not used.
B14	IN	Origin common
B15	IN	Origin input signal (24 V)
B16	IN	Origin input signal (5 V)
B17	--	Not used.
B18	--	Not used.
B19	IN	Interrupt input signal
B20	IN	Emergency stop input signal
B21	IN	Origin proximity input signal
B22	IN	CW limit input signal
B23	IN	CCW limit input signal
B24	IN	Input common

■ External Connection Diagram

This example shows the use of a Servodriver with encoder phase-Z as origin input signals.

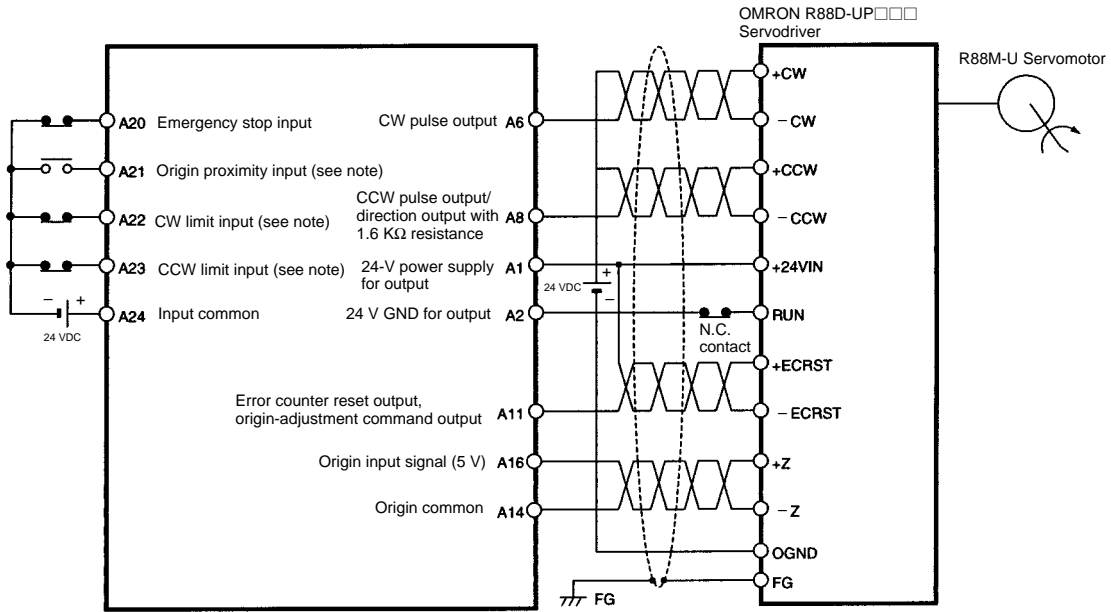

Note: N.O. or N.C. contact can be selected using axis parameters.

■ Combinations of Servo Relay Units, Servodrivers, and Position Control Units

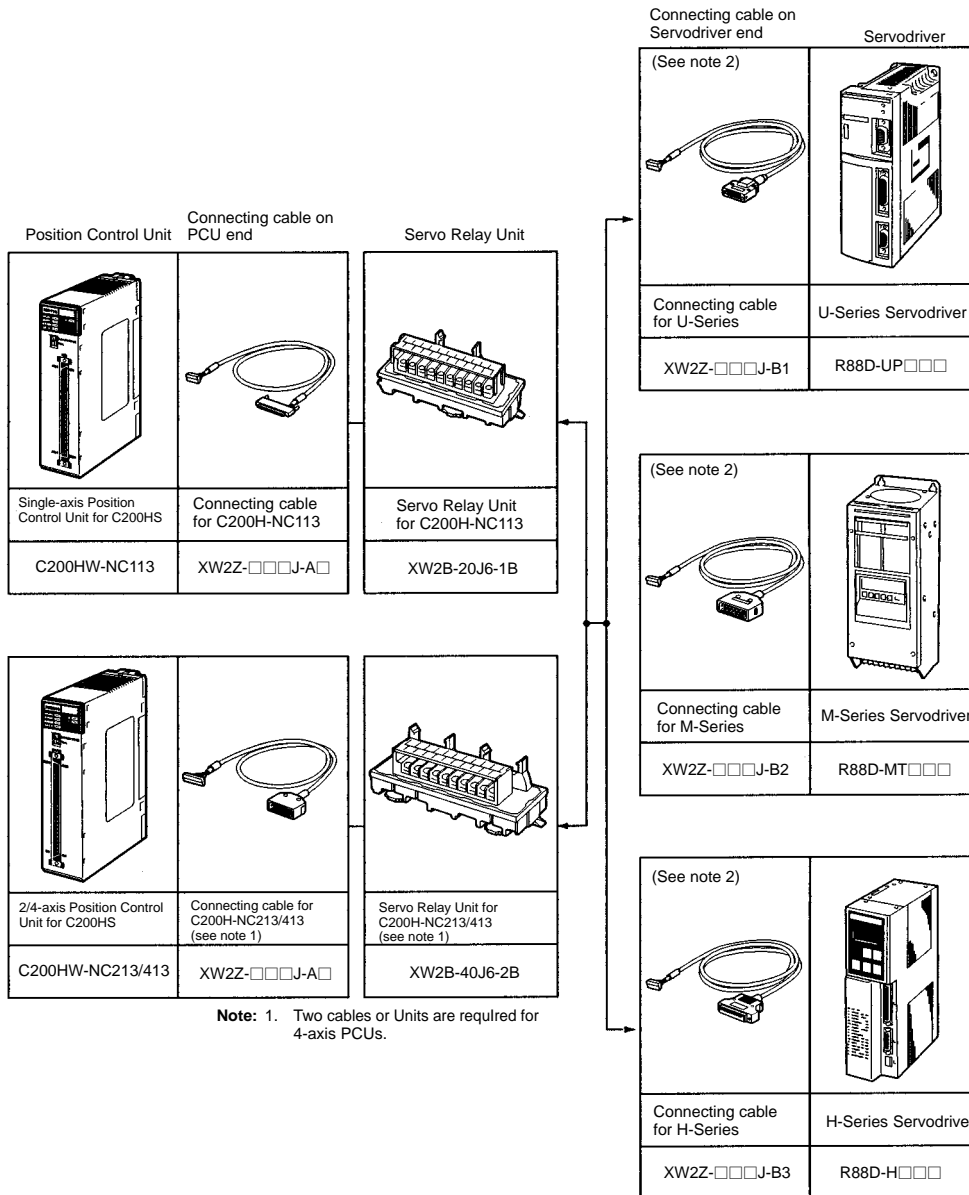

Connection Diagram for Position Control Unit and Servo Relay Unit

XW2Z-□□□J-A6/A8  
Connecting Cable:  
For C200HW-NC113

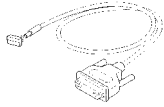

1 axis, U/H/M-Series Servodriver

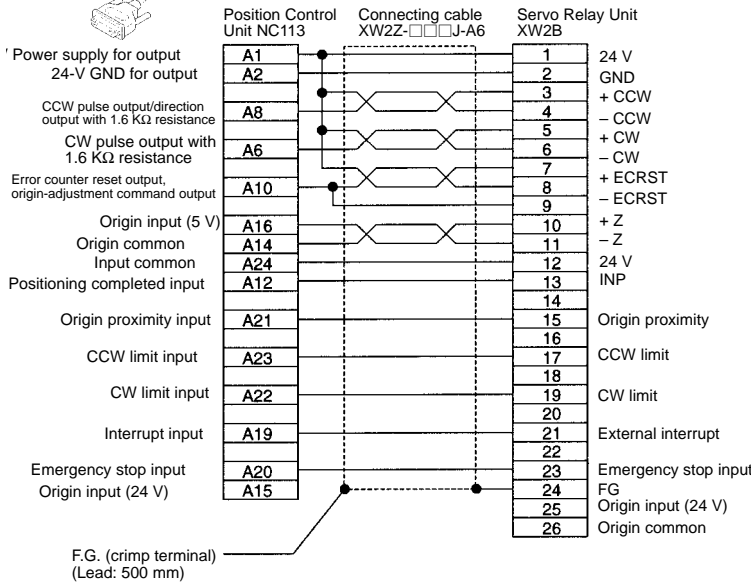

1 axis, UEP-Series Servodriver

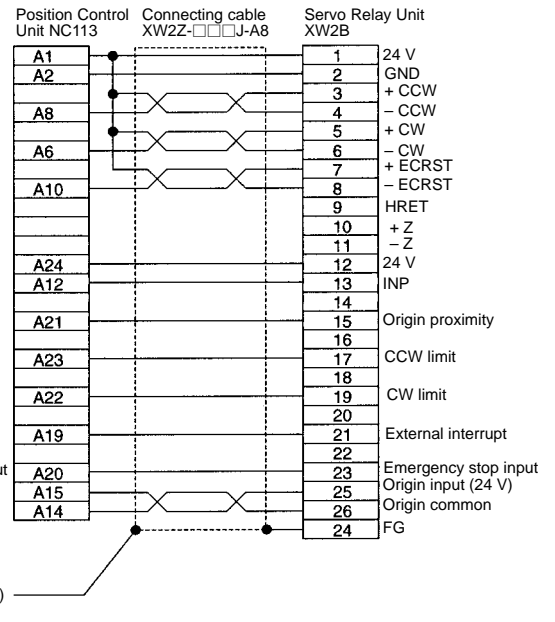

XW2Z-□□□J-A7/A9  
Connecting Cable:  
For C200HW-NC213/NC413

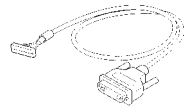

2 axes, U/H/M-Series Servodriver

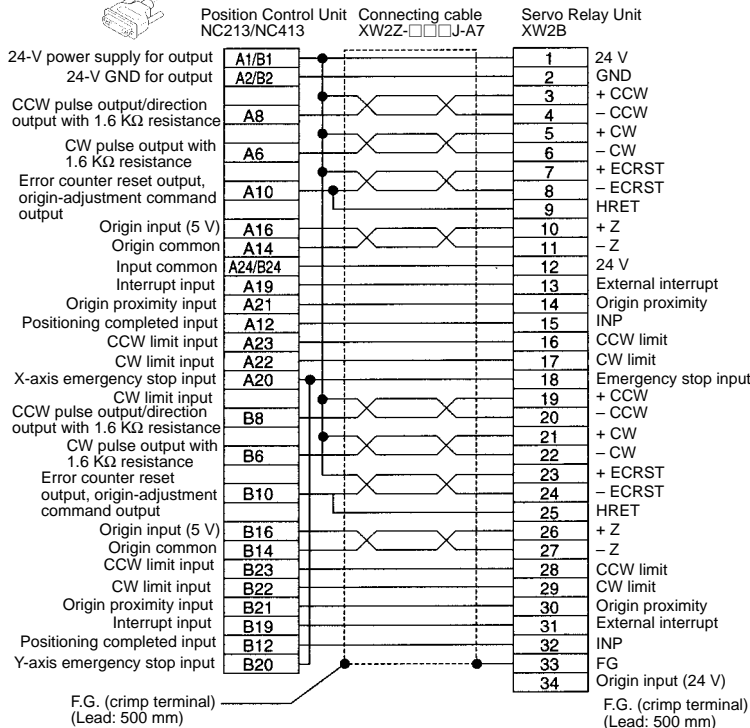

2 axes, UEP-Series Servodriver

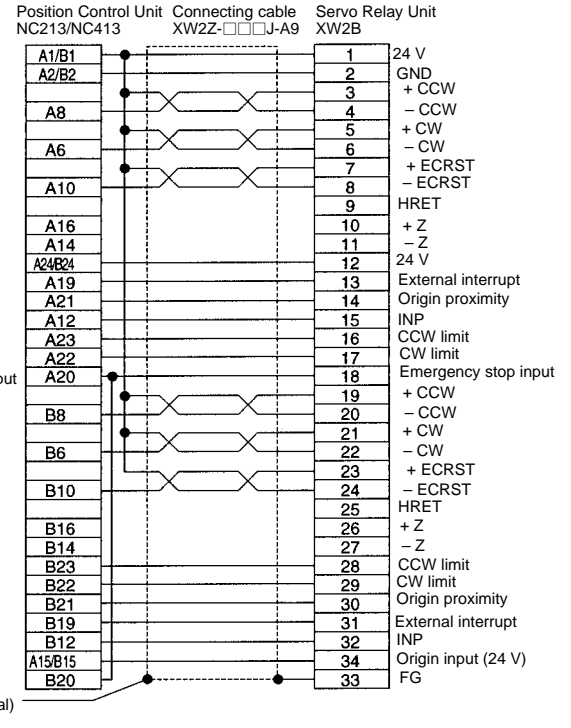

■ Dimensions (Unit: mm)

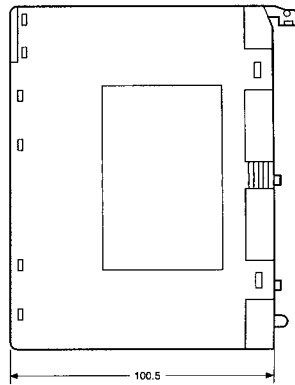
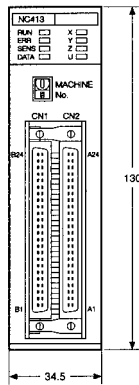
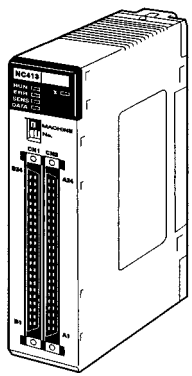

Mounted Dimensions

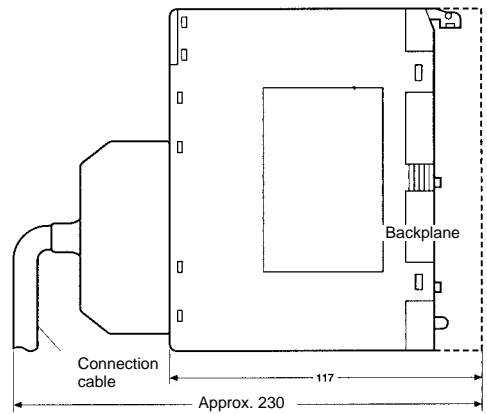

**ALL DIMENSIONS SHOWN ARE IN MILLIMETERS.**  
 To convert millimeters into inches, multiply by 0.03937. To convert grams into ounces, multiply by 0.03527.

**OMRON Corporation**  
Systems Components Division  
66 Matsumoto  
Mishima-city, Shizuoka 411-8511  
Japan  
Tel: (81)559-77-9633  
Fax: (81)559-77-9097

**Regional Headquarters**

**OMRON EUROPE B.V.**  
Wegalaan 67-69, NL-2132 JD Hoofddorp  
The Netherlands  
Tel: (31)2356-81-300/Fax: (31)2356-81-388

**OMRON ELECTRONICS, INC.**  
1 East Commerce Drive, Schaumburg, IL 60173  
U.S.A.  
Tel: (1)847-843-7900/Fax: (1)847-843-8568

**OMRON ASIA PACIFIC PTE. LTD.**  
83 Clemenceau Avenue,  
#11-01, UE Square,  
Singapore 239920  
Tel: (65)835-3011/Fax: (65)835-2711

**Authorized Distributor:**

Note: Specifications subject to change without notice.

Cat. No. R060-E1-1

Printed in Japan  
0100-0.7M